

Revisions				
Zone	Rev	Description	Date	Approved

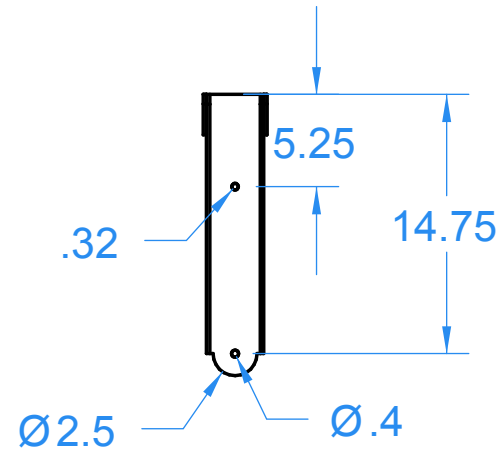
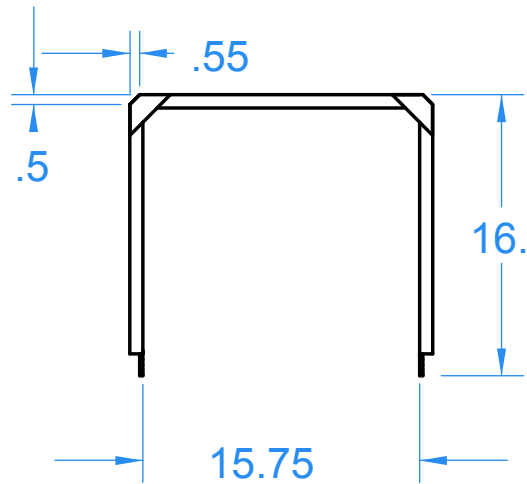
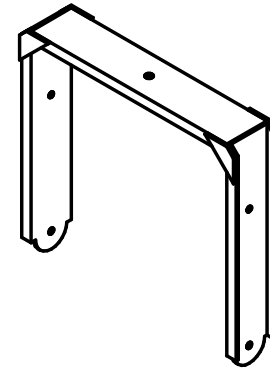
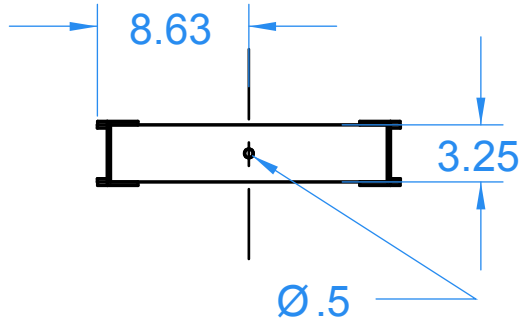

Unless Otherwise Specified: Dimensions in Inches Tolerances: Fractional ± Angular: Mach ± Bend ± Two Place Decimal ± Three Place Decimal ±	Name	Date	Technomad Noho yoke					
	Drawn							
	Checked							
	ENG Appr.							
	MFR Appr.							
	QA							
Material	7g steel	Comments CAD Generated Drawing Do Not Manually Update		Size	Drawing No.	Rev		
Finish	Hot-dip galvanized			A	0001	A		
Do Not Scale Drawing				Scale	1:1	CAD File	Sheet	1 of 1